

Installation Instructions: Urbanline Tractio Decking

Prior to construction, check with your local regulatory agency for local code requirements in your area.

As with any building project, installing Urbanline Tractio will have the best result when you think through the entire process in advance, familiarizing yourself with the materials and the application. Think of how you want the project to finish – i.e. a picture frame border around the deck makes a huge difference to the end result! Please review the following tips before starting work on a Tractio engineered deck.

For additional installation support, call Urbanline Architectural 1800 156 455

The appearance of this product changes when viewed from different ends. To achieve the most consistent colour, install all of the boards in the same direction. Installing boards in opposing directions will create contrasting light and dark shades of the deck board colour and is not covered under warranty.

Storage

Urbanline Tractio engineered decking should be stored covered, flat and off the ground. Standard 5800 mm long packs of Urbanline Tractio require a minimum of eight gluts (supports) under the pack for proper storage.

Safety & Tools

Standard safe practices should, of course, be employed when using any tools during installation. Urbanline Tractio engineered decking can be drilled, sawn, fastened or routed with normal woodworking tools.

Foundation & Sub-Structure

Urbanline Tractio engineered decking is not for use as a component of the foundation or substructure. When constructing the substructure care must be taken to ensure that the joists are level, straight and square as Urbanline Tractio decking will conform to the joists. As a general rule the closer the joists the better the deck. Do not exceed the maximum joist spacing specific for each profile. Residential applications: maximum 400 mm joist spacing's & for diagonal or herringbone designs, 300 mm joist spacing's. Commercial applications: joist spacing's must be approved by registered designer and comply with local building codes. Any overhang of decking boards at the ends or sides of the deck should be kept to a maximum of 50 mm. Breaker boards and all board ends must be positioned above and secured to a joist. A fall of 3-4 mm per metre away from the house should be planned

for water runoff. Urbanline Tractio engineered decking should not be attached directly to any solid surface or watertight flooring system. For adequate airflow and drainage 5 mm between each Urbanline Tractio engineered decking board and a minimum of a 300 mm ground clearance is recommended. Deck board ends should not be occluded and any moisture should be able to drain away freely.

Tractio key product points

- Manufactured out of polypropylene and calcium carbonate (new patented technology).
- Excellent strength to weight ratio. The spans will need to be reduced to 400mm, especially considering the high traffic commercial project.
- Stain resistant
- Cannot be broken in flexural loading or impact (can't break with a sledge hammer!!). Perfect for high traffic areas.
- Impervious to moisture – this can be installed on the ground and IN water! Perfect for the high humidity climate featured with this site.
- Light weight – a lot lighter than other Engineered decks - excellent for pre-fab building.
- Good slip resistance. P4 rating. Results attached.
- High the thermal expansion to the old Latitudes (WPC) decking – low movement
- 3 colours: Dusk (Grey), Mesquite (Brown) and Hickory (Cream).
- Grooved or solid board for hidden deck clips for direct fixing.

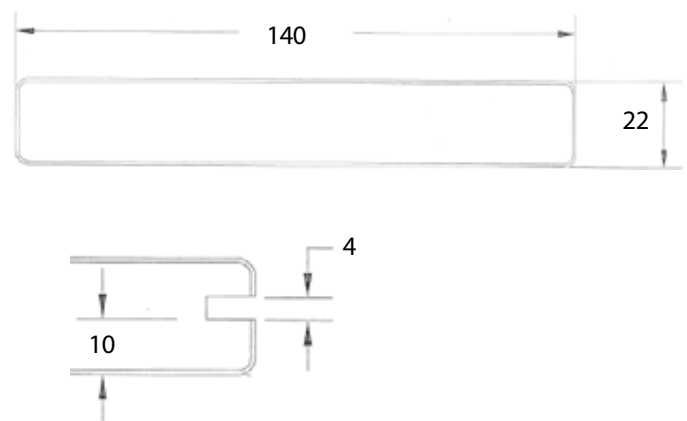

Figure 1: Deckorators® Vault, Voyage, Frontier and Eovations™ Tractio Deck Board Profiles

Tractio Installation Guide

Each Deckorators® Voyage™ and Vault board has a unique appearance and should be arranged according to the end user's preference. Prior to construction, check with your local agency's code requirements. For best results, follow all installation instructions, paying close attention to gapping, spacing and fastener requirements.

Table 1

Joist Spacing Requirements			
	Standard	Picture Frame	Diagonal (45°)
Residential	400mm	400mm	300mm
Commercial	300mm	300mm	300mm

Note: All dimensions are on-center.

Note: Always follow best workmanship practices. Including, and not limited to, square cutting both ends prior to installation.

Table 2

Gapping Requirements		
	Above 0° C	Below 0° C
Side-to-Side	3.2mm	4.8mm
End-to-End	1.6mm	3.2mm
End-to-Side	1.6mm	3.2mm
Abutting Solid Objects	3.2mm	6.5mm

Figure 2

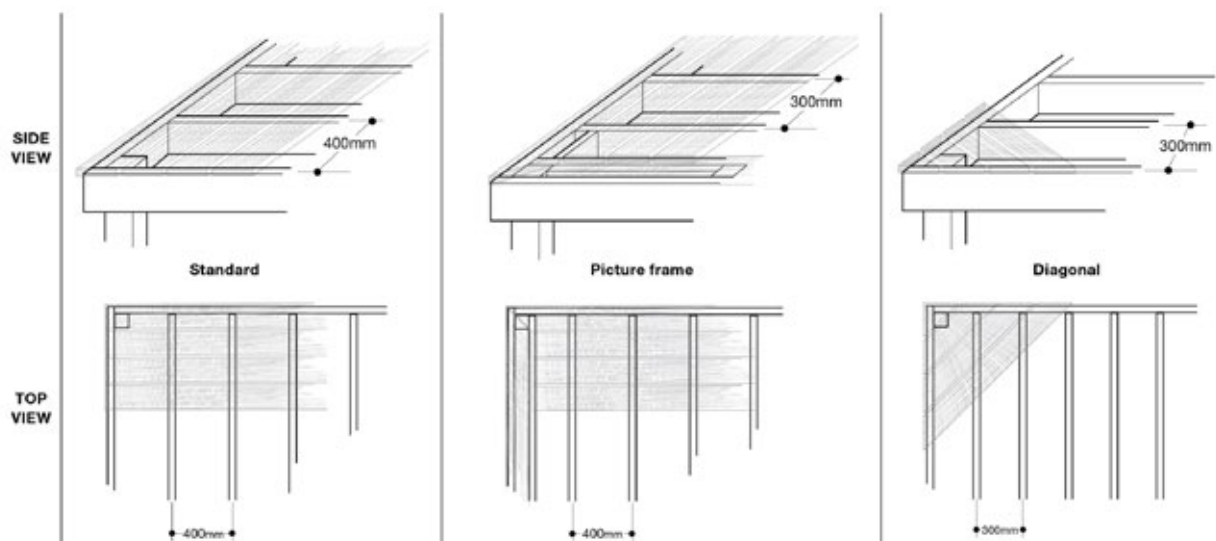

Table 3

Cutting
<ul style="list-style-type: none"> • 255mm 40T, 80T circular blade • 300mm 40T, 72T circular blade

- Upcut with a clean/smooth saw blade.
- Cut deck boards with the leading edge of the saw blade, cutting into the exposed face. Use a sharp utility knife or jigsaw to finish cuts where a circular saw cannot completely cut.
- Use a jigsaw to cut openings for protrusions.
- If necessary, use a largefile or medium-grit sandpaper to clean cut edges.
- Use utility knife to cut any fibers or strands.
(In the rare event that a strand or a fiber protrudes from the board, do not pull it.)

Table 4

Fastener Requirements
<ul style="list-style-type: none"> • Corrosion-resistant, galvanized or stainless steel fasteners • Reverse-thread composite screw • Minimum of 65mm long screws • 32mm minimum penetration into joist

- Set power driver such that screws are slightly counter sunk. Do not overdrive.
- If using a hidden fastener system, use the manufacturer's recommended fastener and follow the manufacturer's instructions.

Installation Instructions: Urbanline Tractio Decking

Installation

- Two fasteners per joist minimum.
- Ends of each board must fall on a joist.
- Double joist or use blocking where two board ends meet.
- 25.5mm maximum cantilever.
- Install entire deck at same temperature.
- Install the deck boards starting from the outside edge of the platform and work toward the other end of the board.
OR: Start installing from the center of the board and work out toward the ends of the board. Do not install by fastening each end first and working toward the middle.
- Continue installing deck boards, adhering to the gapping requirements. Ensure consistent appearance by aligning each plank so that the cathedrals of the emboss pattern point in the same direction.

NOTE: Cutting all ends of boards prior to installation recommended

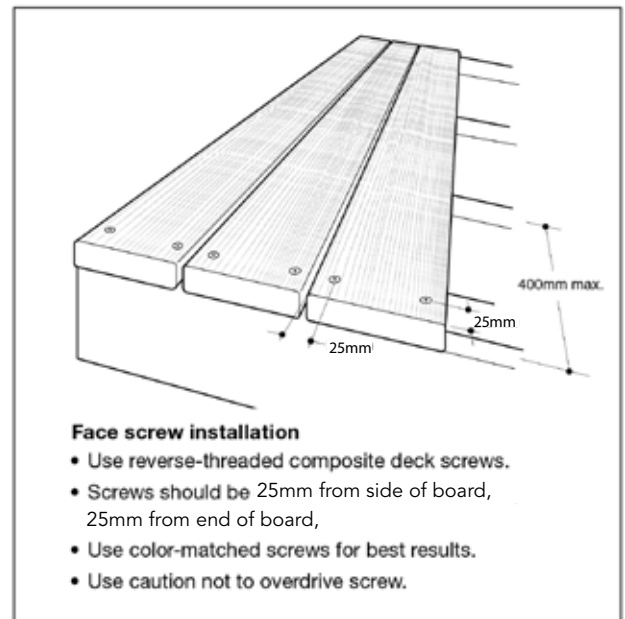

Figure 3

Equator® Hidden Fastener System

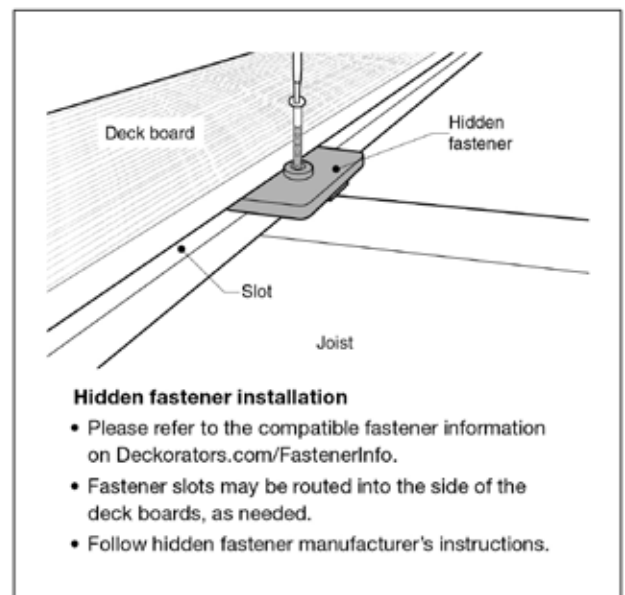
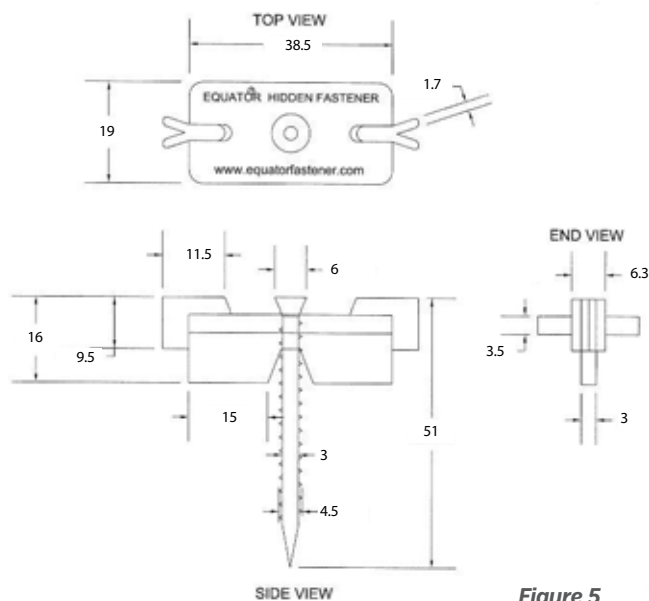

Figure 4

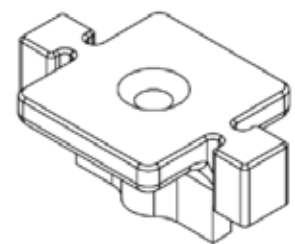

Figure 6 - Deck Board Fasteners

MOD23219 20/02/2019 3

Fastening the boards to the joists

It is recommended that Urbanline Tractio Hidden Fasteners and 305 Stainless Steel Screws are used when installing Urbanline Tractio engineered decking. Standard 60 mm screws with the applicable coating or stainless steel decking screws can be used, however the screw heads will be visible and the added value of the concealed fixing option will be lost. Nailing is not recommended.

Breaker boards, starter boards and finishing boards can be screwed directly through the board into timber joists.

Screw Fixings

Pre-drilling and countersinking is recommended in order to reduce the risk of splitting when screwing directly in to the face of the Urbanline Tractio engineered decking. A minimum screw length of 60 mm is required. Drivers should be adjusted to a low or medium torque setting when fixing screws in to Urbanline Tractio engineered decking. Screws should not be over tightened into the decking. Screw fixing directly through the Urbanline Tractio board is not recommended on steel joists due to the different expansion and contraction characteristics of the two materials.

Gapping

Urbanline Tractio boards are designed to be installed with adequate gapping around the boards to aid air flow. Using Hidden Fastener deck clips to fix the boards to the joists sets a gap between the sides of each board and is the preferred fixing method.

Urbanline Tractio engineered decking expands when warm and contracts when cold. It is important to be cognisant of the board temperature prior to cutting in order to determine the gap requirements when installing the decking

It is advisable to have all of the boards at the same temperature by spreading them evenly over the deck surface prior to installation. In hot conditions, keep the boards in a shaded area before cutting and fixing.

Equator Hidden Fastener Installation

Fourteen Equator Hidden Fasteners are required per 5800 mm board if mounted on 400 mm centre joists. Equator Hidden Fasteners can be installed in just four easy steps:

1. Place an Equator fastener in the slot of the engineered deck board at each support joist.
2. Insert a stainless steel screw through each fastener into the joist.
3. Slide the next deck board into place so that the wings fit into the slot on the deck board side.
4. Repeat this process until the deck is complete.

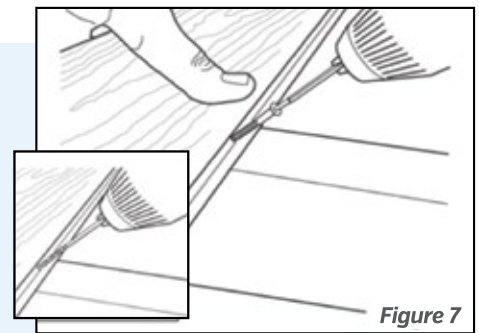

Figure 7

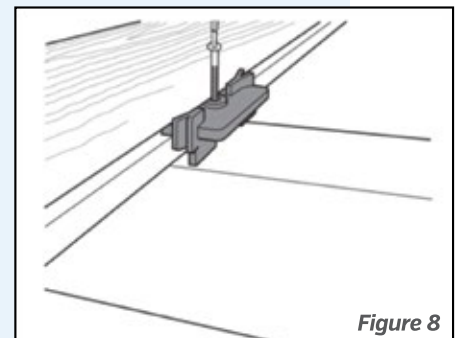

Figure 8

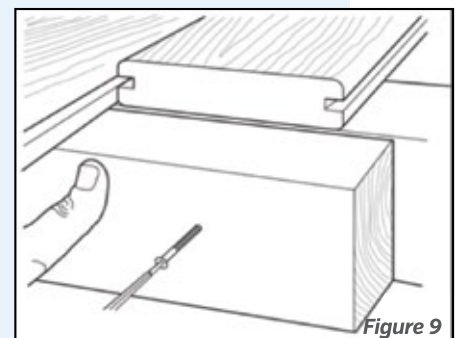

Figure 9

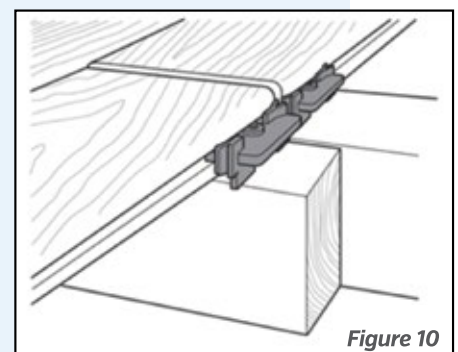

Figure 10

Apply these same principles when installing stair treads.

To keep the interior boards from moving over time, we recommend pinning the boards at the centre of their length using a stainless steel screw. This holds the deck board in place at the centre of each board and allows the decking to expand/contract at the ends of the boards. Pre-drill in the slot of the deck board with a 3.2mm drill bit (*inset of figure 7*). Drive screw into the slot so it's flush with the bottom of the groove (*figure 7*). This will allow you to properly fit an Equator hidden fastener into the slot. Install Equator hidden fastener clip over the screw and centred over the joist. Fasten using the stainless steel screw at a 90° angle through the Equator hidden fastener and drive flush with the clip (*figure 8*). The fastener wings must remain level with the joist for the next board to fit correctly.

Install one Equator fastener at each joist location along the length of the board. For installations where deck boards are butted end-to-end at the joist, we recommend adding a timber block and using an Equator hidden fastener clip at the end of each board (*figures 9 and 10*). Be sure to gap the boards as previously described. Repeat the process for each board until the outside edge of the final board is fastened with screws. Use fascia to conceal the board profile and inhibit board movement over time. If no fascia is being used, the entire perimeter of the deck should be fastened to the rim joist with screws. Use two fasteners at the end of each board.

The diagrams and instructions in this brochure are for illustration purposes only and are not meant to replace a licensed professional. Any construction or use of the product must be in accordance with all local zoning and/or building codes. The consumer assumes all risks and liability associated with the construction or use of this product. The consumer or contractor should take all necessary steps to ensure the safety of everyone involved in the project, including, but not limited to, wearing the appropriate safety equipment.

Except as contained in the written limited warranty, the warrantor does not provide any other warranty, either express or implied, and shall not be liable for any damages, including consequential damages.

Deckorators Tractio Fascia installation instructions

Table 5

Tools and Items Needed	
<ul style="list-style-type: none"> • Drill/power screwdriver • 3.2mm drill bit • Circular saw with carbide-tip blade • 60mm composite wood deck screws • Tape measure • Carpenter's pencil • Safety glasses/goggles 	<p>Notice to installers</p> <ul style="list-style-type: none"> • DO NOT use cordless impact drivers • Set drill speed to 1500-1750 RPM • Max torque not to exceed 2.6Nm • Pre-drill knots or dense hardwood

Attach fascia to the rim joist using 3 screws spaced no further apart than 400mm on-center. Fasten the fascia from one end to the other, or from the center out to each end. Never fasten the fascia from both ends to the center. Leave a 3.2mm space between the fascia ends where two pieces meet or wherever a piece meets a solid surface (i.e., a corner or a building wall) to allow for expansion of the material. Use one of the recommended installation configurations below for best results. Do not install fascia board flush with decking that runs perpendicular [see figures 1-4 for possible configurations to conceal 2x10 and 2x12 joists]

Note: Deckorators decking is not suitable for structural use. It should not be used for primary load-bearing members such as posts, joists, beams or stringers. The same common sense precautions should be taken when handling Deckorators products as with any wood or other building materials. Dust masks and eye protection devices are recommended to avoid possible irritation from sawdust and chips. Gloves will help protect hands. Hands should be washed after construction work.

The diagrams and instructions in this brochure are for illustration purposes only and are not meant to replace a licensed professional. Any construction or use of the product must be in accordance with all local zoning and/or building codes. The consumer assumes all risks and liability associated with the construction or use of this product. The consumer or contractor should take all necessary steps to ensure the safety of everyone involved in the project, including, but not limited to, wearing the appropriate safety equipment.

Except as contained in the written limited warranty, the warrantor does not provide any other warranty, either express or implied, and shall not be liable for any damages, including consequential damages.

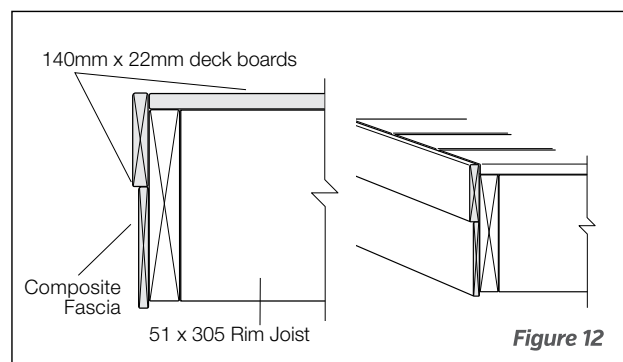
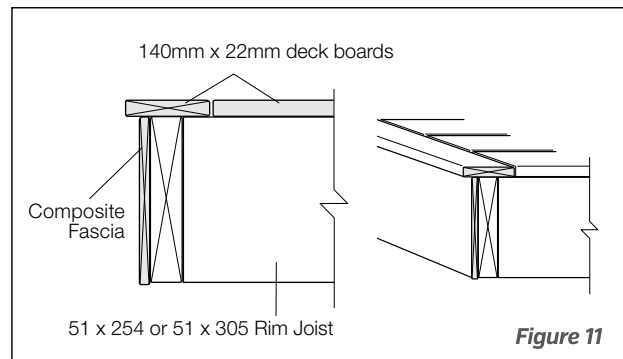

Note: Always follow best workmanship practices. Including, and not limited to, square cutting both board ends prior to installation.

Installation Instructions: Urbanline Tractio Decking

Stair Installation

- Stairs must be constructed according to national and local building codes. Generally, building codes require 76mm minimum wide treads and 280mm minimum tread depth.
- 230mm maximum center-to-center spacing of stringers is required.
- 12.5mm maximum tread overhang over stringers.
- 3.5mm minimum gap between stair-tread boards. Local building codes may require the gap to be increased to 10mm in order to maintain the minimum tread depth.

Color Variation

Like most composites, Deckorators Decking will have color variations from piece to piece. This is due to naturally occurring variations in polymers. Purchasing all required decking material at one time is recommended, as manufacturing runs can produce slightly different colors. Do not install if color variation is not acceptable.

Mold and Mildew Growth

Mold and mildew can be a nuisance on any exterior building surface, regardless of the material. If the conditions are right, they will grow on wood, plastic, concrete, metal and other surfaces. Mold formation is most prevalent in consistently wet, shaded areas. Spores from the natural environment are carried by the wind and commonly land on decks surfaces. It is important to note that the appearance of mold/mildew is a function of nature, not necessarily a deficiency with any of the material on which it grows.

Cleaning

Periodic washing with soap/mild detergent and water will help remove surface dirt. This will also help prevent the buildup of pollen, debris and spores that can cause and accelerate mold/mildew growth.

Caution: A pressure washer should not be used to “blast” mold/mildew or soils from a deck surface. The abrasive nature of the water stream can potentially cause damage by driving the spores deeper into the material, which may create a more challenging problem to remedy. A pressure washer with a fan-tipped nozzle should be used only to lightly wet or rinse wood or composite deck surfaces.

There are many deck wash and exterior cleaning products available at retail. It is important to make sure you use a cleaner specifically intended for your application. After selecting a product, be certain to read, understand and follow all instructions supplied by the manufacturer. Some cleaning products and inhibitors may be more

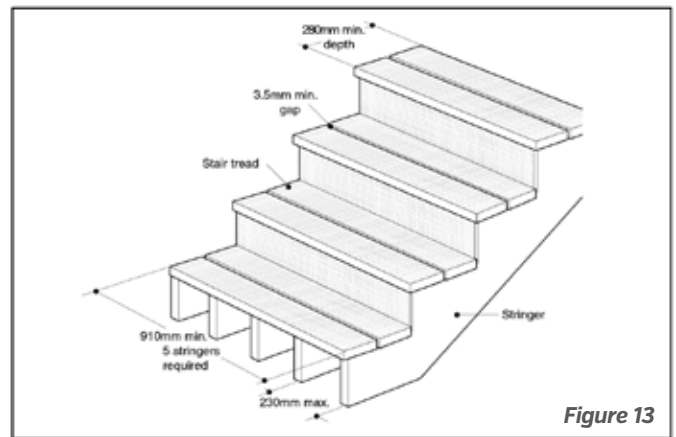

effective than others, depending on the environmental conditions your deck is subjected to. Additionally, it is always a good idea to test the cleaner in a small, inconspicuous area prior to applying it to the entire deck (www.deckorators.com).

Tips for snow removal: Care should be taken when removing snow from your deck to avoid damaging the deck surface. Use a plastic snow shovel, one without a metal edge. A stiff push broom can work very well and minimizes lifting. Light snow can be cleared using a leaf blower. Do not attempt to break up or scrape ice from the deck surface; use ice melt products when needed. No concerns have been reported using ice melt products labeled “Safe for Pets”.

Mold Inhibitors

As with deck washes, there are several mold-inhibitor products available from paint stores, hardware stores, online outlets and home centers to help prevent long-term mold/mildew growth. For any product selected, be certain to read, understand and follow all instructions provided by the manufacturer. Depending upon the environmental factors affecting your deck, some preventive cleaning products may be more effective than others. It may be necessary to try more than one product. For ongoing preventive maintenance, follow the manufacturer's recommendation.

Note: Deckorators is not suitable for structural use. It should not be used for primary load-bearing members such as posts, joists, beams or stringers. The same commonsense precautions should be taken when handling Deckorators as with wood or other building materials. Dust masks and eye protection devices are recommended to avoid possible irritation from sawdust and chips. Gloves will help protect hands. Hands should be washed after construction work.

Code Compliance Research Report CCRR-0195 [Specific to the USA]

REPORT SUBJECT:

Eovations™ Deck Boards

Eovations™ Porch Boards

Deckorators® Vault Deck Boards also known as Deckorators Voyage and Eovations Tractio

Deckorators® Frontier Deck Boards

SLS Composite Deck Boards

Ultra Light Deck Boards

1.0 Scope Of Evaluation

1.1. This research report addresses compliance with the following Codes [Specific to the USA]:

- 2018, 2015 International Building Code® [IBC]
- 2018, 2015 International Residential Code® [IRC]

1.2. Deck and porch boards have been evaluated for the following properties:

- Structural Performance
- Durability
- Surface Burning

1.3. Eovations™, Deckorators®, SLS Composite, Ultra Light deck and Porch boards are intended for use as a walking surface on exterior decks, balconies, porches, and walkways, including stairs as further defined herein.

1.4. The deck and porch boards identified in this report may be used in One- and Two-Family Dwellings regulated by the IRC and other construction types regulated by the IBC in accordance with IBC Section 1406.3 as follows [Specific to the USA]:

Construction Type IIB, IIIB & VB per IBC §1406.3 and Table 601
[No fire resistance rating required for floors]

Construction Type IIIA, IV & VA per IBC §1406.3, Exception 3
[Sprinkler protection required]

2.0 Statement Of Compliance

Eovations™, Deckorators®, SLS Composite, Ultra Light deck and Porch boards comply with the Codes listed in Section 1.1, for the properties stated in Section 1.2 and uses stated in Section 1.3, when installed as described in this report, including the Conditions of Use stated in Section 6.

3.0 Description

3.1. Eovations™, Deckorators®, SLS Composite, Ultra Light deck and Porch boards are thermoplastic composite deck boards, co-extruded using proprietary inorganic fillers and polypropylene [PP] materials with a polypropylene cap.

3.2. Finished deck boards are available in solid or slotted rectangular profiles.

3.3. Deckorators® Vault and Frontier deck boards are provided with nominal dimensions of 140mm wide and 22mm thick. See Figure 1.

3.4. Deck boards may be installed via face-fastening using exterior screws or by using hidden fastener systems.

4.0 Performance Characteristics

4.1. Deck and porch boards are rated for a uniform live load of 488kg/m² when installed on support framing spaced at up to 400mm.

4.2. Deck and porch boards used as stair treads are rated for the code-prescribed concentrated load equal to 135 kg when installed with a maximum 230mm support span. Deck and porch boards used as stair treads shall be installed in a minimum two-span condition.

4.3. Deck and porch boards have wind uplift resistance ratings as determined by the fastening method. See Table 6.

4.4. Materials used have a flame spread index no greater than 200 when tested in accordance with ASTM E84.

4.5. Materials are deemed equivalent to preservative treated or naturally durable wood for resistance to weathering effects, attack from termites and fungus decay.

4.6. Structural performance has been demonstrated for a temperature range from -29°C to 51.67°C.1

5.0 Installation

Installation shall be in accordance with the manufacturer's installation instructions and this report. Where differences occur between this report and the manufacturer's installation instructions, this report shall govern.

5.1. Solid deck boards may be installed with #7 x 25-22mm Camo™ hidden fasteners. Two fasteners are required at every joist.

5.2. Slotted deck boards are installed with the Equator®, or Stowaway™ hidden fastener systems. For the Equator® and Stowaway™ hidden fasteners, one fastener is required at every joist.

6.0 Condition Of Use

The deck board applications identified in this report are deemed to comply with the intent of the provisions of the referenced building codes subject to the following conditions:

6.1. Deck and porch boards placed at an angle other than 90 degrees to the supporting joist will require support framing at a reduced spacing such that the span of the board does not exceed 16 inches.

6.2. The wind uplift resistance rating recognized in this report is based on attachment to treated Southern Pine framing (specific gravity, G=0.55). Installation on wood framing with a lesser specific gravity may result in a lower wind uplift rating.

6.3. Where required by the building official, engineering calculations and details shall be provided. The calculations shall verify that the anchorage complies with the building code for the type of framing and condition of the supporting construction.

6.4. Compatibility of the supporting construction materials with all metal fasteners are subject to approval by the code official.

6.5. Only those types of fasteners and fastening methods described in this report have been evaluated for the installation of the deck boards; other methods of attachment are outside the scope of this report.

6.6. Eovations™, Deckorators®, SLS Composite, Ultra Light deck and Porch boards are manufactured in accordance with the manufacturer's approved quality control system with inspections by Intertek Testing Services NA, Inc.

7.0 Supporting Evidence

7.1. Manufacturer's drawings and installation instructions.

7.2. Reports of testing and engineering analysis demonstrating compliance with ICC-ES AC174, Acceptance Criteria for Deck Board

Span Ratings and Guardrail Systems (Guards and Handrails), dated January 2012, editorially revised December 2014, and ASTM D7032-10a [-14 for 2018 IBC] (Specific to the USA).

7.3. Documentation of an Intertek approved quality control system for the manufacturing of products recognized in this report.

8.0 Identification (Specific to the USA)

Eovations™, Deckorators®, SLS Composite, Ultra Light deck and porch boards produced in accordance with this report shall be identified with labeling on the individual deck boards that includes the following information: Name and/or trademark of manufacturer; the Code Compliance Research Report identification and number (CCRR-0195); and the following statement: "See Intertek CCRR-0195 at <https://bpdirectory.intertek.com> for uses and performance levels."

9.0 Other Codes

This section is not applicable.

10.0 Code Compliance Research Report

10.1. Approval of building products and/or materials can only be granted by a building official having legal authority in the specific jurisdiction where approval is sought.

10.2. Code Compliance Research Reports shall not be used in any manner that implies an endorsement of the product by Intertek.

10.3. Reference to the Intertek website address: <https://bpdirectory.intertek.com> is recommended to ascertain the current version and status of this report.

Table 6

Span and Uplift Resistance Ratings				
Product	Live Load (mm / kPa)	Stair Tread Support Spacing (1)	Fastener (2)	Uplift Resistance
Eovations™ Tractio	406 / 4.8	230mm	#7 x 40mm Camo™ coated steel screw	54 T/m ²
			Equator® Hidden Fastener	30 T/m ²
			Stowaway™ Hidden Fastener	35 T/m ²

[1] Continuous two-span installation.

[2] As described in Table 2.

Table 7

Fastener Description and Uplift Resistance Ratings		
Generic Fastener Description	Uses	Detailed Fastener Description
Equator® Hidden Fastener (Figure 5)	Hidden Fastening system for slotted deck boards (see Section 5.2)	Polypropylene Clips 2.5 pitch with a 50mm overall length, 4.5mm major diameter, 6mm head diameter, square drive trim head, type 17 point
Stowaway™ Hidden Fastening System (Figure 5)	Hidden Fastening system for slotted deck boards (see Section 5.2)	Nylon Composite Clips fastened to joists with #7 by 40mm long stainless steel screw (4mm major diameter, 3mm shank diameter, 6mm in head diameter)
“L” cleat nail (Figure 6)	Fastening system for tongue and groove porch boards (see Section 5.2)	1.3mm x 51mm Freeman “L” Cleat Flooring Nail installed using a pneumatic flooring tool
“T” cleat nail (Figure 6)	Fastening system for tongue and groove porch boards (see Section 5.2)	1.3mm x 51mm Freeman “T” Cleat Flooring Nail installed using a pneumatic flooring tool