

# Technical Manual



International

**PRIMA**<sup>TM</sup>**ACTU**

# Introduction

**PRIMACTU™** is a premium quality autoclaved cellulose fibre reinforced cement board manufactured from portland cement, top grade quality pulp from New Zealand, finely ground sand and water by Hume Cemboard Industries Sdn Bhd, an MS ISO 9001:2000 accredited company.

**PRIMACTU™** has superior fire performance and dimensional stability, which makes it an ideal substrate for ceramics tiles in wet and dry areas.

Manufactured with a pre-marked nailing pattern, sheets can be easily laid on existing timber flooring with minimal surface preparation.

# Contents



## Product Specifications Overview

---

- Product Description
- Basic Composition
- Moisture Content
- Building Code Compliance
- Standard Sizes and Mass

## PRIMACTU™

---

### Substrate for Tiles

- Installation Instructions
- Expansion Gap and Joint
- Tiling and Grouting

### Working Instructions

---

- Delivery, Handling and Storage
- Cutting Methods
- Notching
- Penetrations
- Maintenance
- Working safer with PRIMA Products

# Product Specifications Overview



## Product Description

**PRĪMACTU™** is manufactured to nominal 6.0mm thickness. The material is suitable for use as a substrate for ceramic floor tiles on existing floorboards with minimal surface preparation. The product has preprinted fastener points for ease installation.

## Fire Performance

**PRĪMACTU™** have been tested by CSIRO Australia to AS 1530.3 and have achieved the following indices.

### Early Fire Hazard Indices

Ignition Index	0
Spread of Flame Index	0
Heat Evolved Index	0
Smoke Developed Index	0-1

**PRĪMACTU™** are deemed incombustible in accordance with BCA.

## Basic Composition

Basic ingredients of the products are Portland cement, finely ground sand, quality pulp from NZ and water.

## Moisture Content

Moisture content at EMC is approximately 7% and at saturation is 33%.

*Note: Where values are stated at EMC, the ambient temperature is 27°C ± 2°C and relative humidity is between 65% - 95%*

## Building Code Compliance

The requirement set out in the Building Code and local Building Regulatory Authority must be checked and verified prior to the commencement of work to ensure their compliance.

## Appraisals

### Serviceability Life

The performance of **PRĪMA** products is limited only by the durability of the supporting structure and the materials used in the installation. When installed and maintained as per good building practice and specifications described in this manual, **PRĪMA** products are expected to have a minimum serviceability life of 50 years\*.

*\*Appraised by BRANZ based on New Zealand Building Code*

PRĪMACTU™		
Appearance	Smooth surface with pre-marked fixing positions, square edge.	
Mass at EMC	8.5kg/m <sup>2</sup>	
Thickness (mm)	6.0mm	
Length (mm)	Width (mm)	
1800mm	900mm	1200mm Victoria Only

*Note:*

1. Other sizes may be available upon special order and may be subject to special conditions.

2. The mass per unit area given should NOT be used for calculating the weight for transportation purposes. For packing details, contact our office or our nearest agent in your area.



## Installation Instructions

### Preliminary Preparation

Ensure that the underside of the existing floor is adequately ventilated. Check and replace any damaged floorboards and firmly re-nail any loose boards. The floor surface should be reasonably flat. Rough sand any undulations prior to fixing the ceramic tile underlay.

### Underlay Orientation

PRIMACTU™ sheet should be laid in a staggered or brick pattern, across the direction of floorboards. Sheet joints must not coincide with floorboard joints.

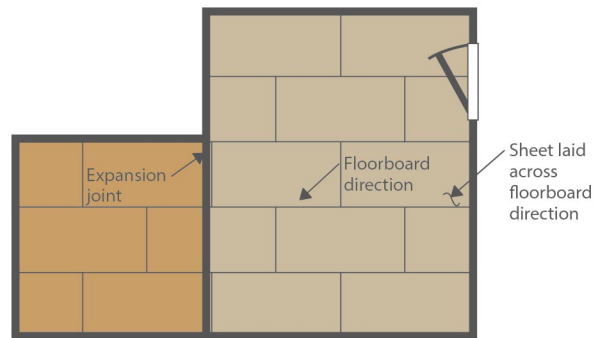
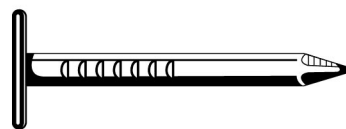

Figure 1: Underlay Orientation

### Fixing Method

Nail underlay sheet at the pre-designated fixing locations with 25mm x 2.5mm diameter annular threaded underlay nails. Nail fixing distances must be as follows:



- 12mm minimum from sheet edge
- 50mm minimum from corner
- 75mm maximum centres spacing at perimeter
- 150mm maximum centres spacing at sheet centre

Drive nail head flush with the surface of the underlay sheet. Start nailing from the sheet centre and work outwards toward the sheet ends and edges.

**Notes:**

For fixing to particleboard or plywood floor, apply wallboard adhesive to the sheet back face with a notched trowel in addition to nail fixing as specified above.

# PRIMACTU™ Installation Instructions

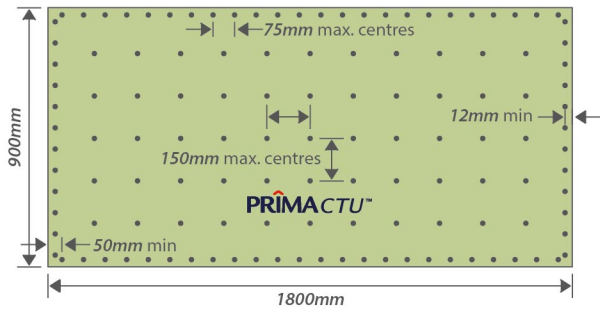

Figure 2: Nail Fixing Locations

## Expansion Gap and Joint

### Perimeter Expansion Gap

Leave a 3mm gap between sheet edges and wall at the wall-to-floor junction.

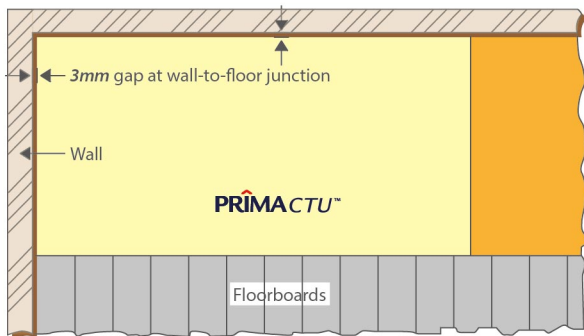

Figure 3: Perimeter Expansion Gap

### Expansion Joint

Expansion joints must be provided at 5.0m maximum centres and must always coincide with the structural break joints of the existing floor structure. Do not tile over an expansion joint. Refer to Figure 4.

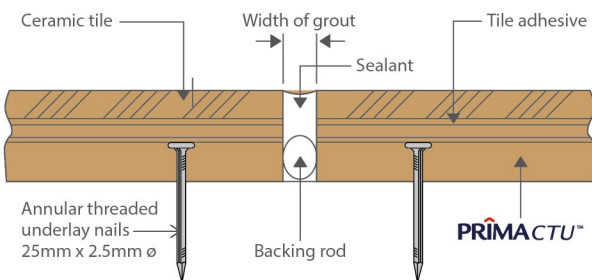

Figure 4: Detail at Expansion Joint



## Tiling and Grouting

Use only flexible tile adhesives that comply with AS 2358 - Adhesive For Fixing Ceramic Tiles. Refer to tile adhesive manufacturer for recommendations. Tile grout should be fully compressible.

Tiles should be laid in accordance with acceptable tile laying practice. Provide a minimum of 2 to 3mm gap between each tile.

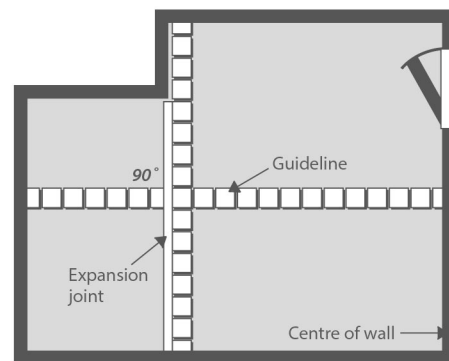

Figure 5: The Laying Guide

# Working Instructions

## Delivery, Handling And Storage

- To minimize the possibility of on-site damage, sheets should be delivered just prior to installation.
- Always lift sheets vertically, (on-edge) lengthwise.
- Store sheets neatly on a flat surface supported evenly with bearers spaced at 600mm centres maximum, clear of the ground to avoid damage and moisture ingress.
- Store under cover and ensure sheets are dry prior to fixing. Never install damp sheets. Damp sheets must be allowed to dry to equilibrium moisture content (EMC) before fixing.
- Protect edges and corners from damage on site.

*Note - Floor loadings should be considered when stacking sheets.*



# Working Instructions

## Cutting Methods

A dust mask and safety glasses should always be worn when cutting, drilling or grinding. Dry cutting with power tools should be performed in a well-ventilated area or open-air situation using a power-saw fitted with dust-extracting attachments.

A circular saw with dust collecting facilities should have carbide-tipped teeth or a carborundum blade.

## Scoring and Snapping

Any scribing tool or special tungsten-tipped scoring knife can be used for this method of cutting, refer to Figure 6.

- Score the face of the **PRIMA** board, repeating the action to obtain a depth of about 1/3 of sheet thickness.
- Snap the off-cut upward to achieve cut. If the edge is rough, trim with a rasp.

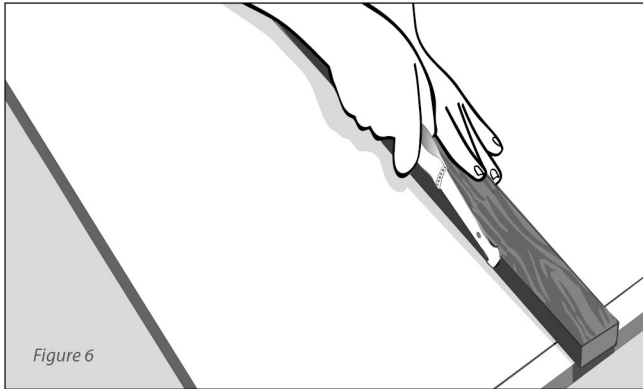

## Hand Guillotine

When using a hand guillotine, best results are obtained when the board and the off-cut are both fully supported, refer to Figure 7.

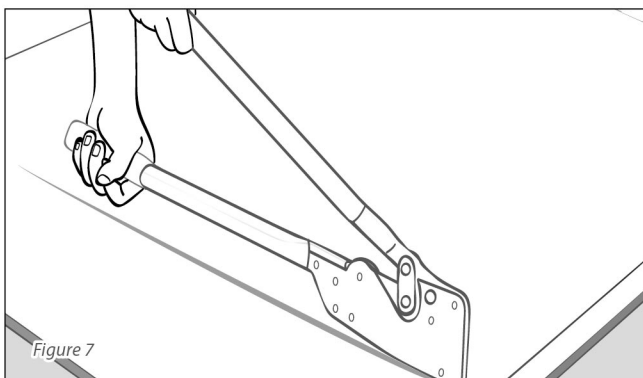

## Notching

Use hand saw to cut the sides of the notch. Score along the back of the notch with scoring knife and snap the waste piece upwards, refer to Figure 8.

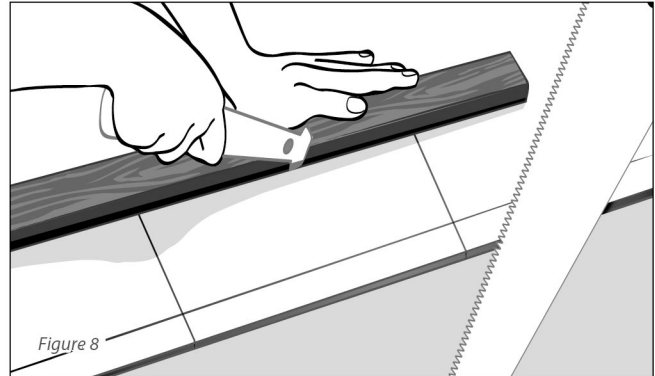

# Working Instructions

## Penetrations

Round holes may be cut using a power drill with a tungsten tipped hole saw attachment. Alternatively rectangular or circular holes may be formed by using a masonry drill to make a series of smaller holes around the perimeter of the proposed opening, and then tapping out the waste section carefully, refer to Figure 9.

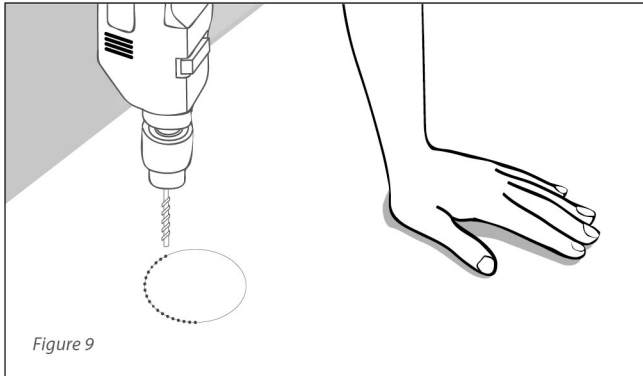

Figure 9

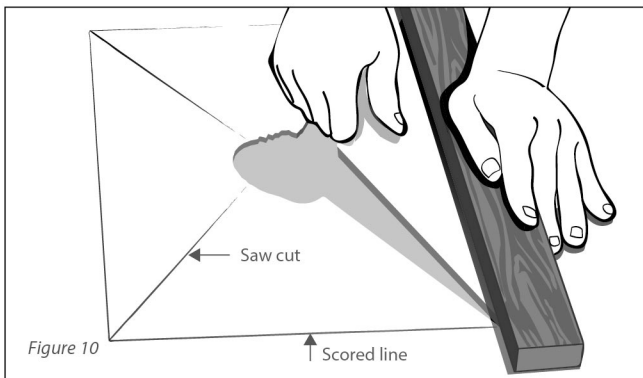

Figure 10

Larger rectangular holes and openings can be made using the following procedure, refer to Figure 10.

- Score the perimeter of the hole using a scoring knife.
- Drill a larger circular hole at the centre of the proposed opening.
- Use a saw to cut from the centre to the corners of the proposed opening.
- Hold a straight edge or a piece of wood along the scored line and snap the waste piece upwards.

## Maintenance

Periodic maintenance of the coating and finishes must be performed as specified by the manufacturer. The jointing systems should also be inspected periodically during the life of the building. All joints and sealant must be checked for cracks to prevent the intrusion of water. Make good any defects in accordance with the systems outlined in this manual and good building practices.

## Working Safer With Prima Products

- Always work in a well-ventilated area.
- Dust extraction equipment should be fitted to all power cutting tools.
- Wear safety goggles conforming to AS 1337.
- Wear protective clothing.

## Warning

Breathing dust from silica based products such as fibre cement can be hazardous over an extended period of time. Always use a mask, protective equipment and clothing that complies with the latest regulations of Occupational Safety and Health (OSH) or Workplace Health and Safety.







Termite Resistant

Fire Resistant

Water Resistant

Weather Resistant

Environmentally Friendly

Superior Paint Adhesion

High Workability

Aesthetically Pleasing

50 Years Durability

**WARRANTY**

Hume Cemboard Industries Sdn Bhd ("the Company") warrants that it will at all times ensure that the products referred to herein ("the Products") shall be supplied by it to the purchaser free of any manufacturing defects and defective materials used in their manufacture.

In the event and if contrary to this assertion the Products prove to be defective, whether as a result of manufacturing defects or arising from the Company's use of defective materials, the Company will supply replacement Products. The Company shall, however, have the option and may choose to reimburse the purchaser the purchase price of the Products instead. The Company shall not be liable for any economic or consequential losses arising from any use of defective Products.

This warranty shall be void unless the purchaser has, in its handling and installation of the Products, complied with the recommendations contained in this brochure and other good building practices expected of a reasonable purchaser.

**ADVISORY NOTE**

Successful installations of Hume Cemboard Industries Sdn Bhd's Products depend on a large number of factors that are outside of the scope of this brochure. Particular design, detail, construction requirements and workmanship are beyond the control of the Company. As such, Hume Cemboard Industries Sdn Bhd's warranty does not extend to non-usability of Products or damage to Products arising from poor or defective designs or systems or poor quality of workmanship in the installation of Products.

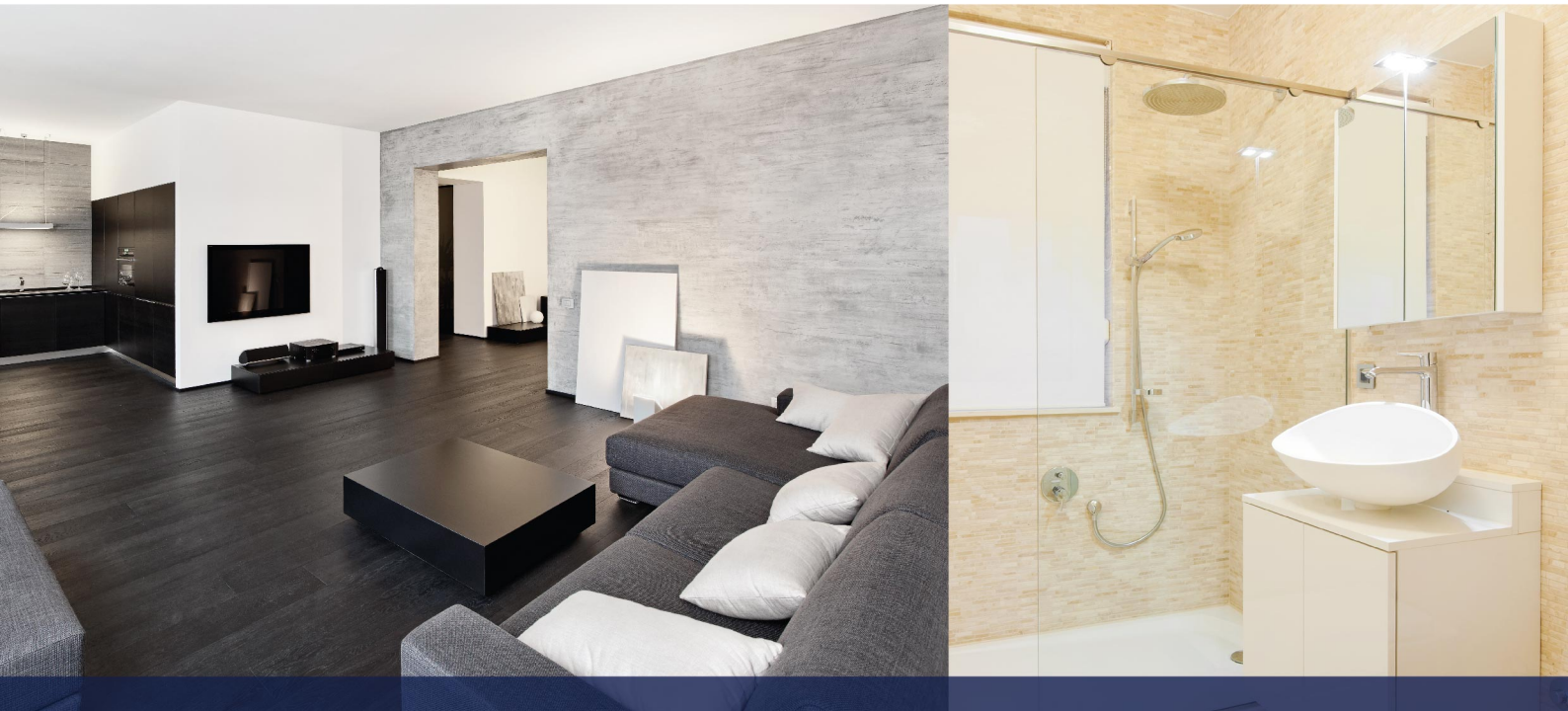

For more information, please contact us at:

**Hume Cemboard Industries**

A Member of the Hong Leong Group

No. 12 Jalan Tandang, 46050 Petaling Jaya, Selangor, Malaysia.

Tel: +603 7781 1977, +603 7625 9999, + 603 7625 3880

Fax: +603 7625 7822, +603 7625 3990

Email: sales@humeceboard.com.my

[www.primafibreceement.com](http://www.primafibreceement.com)

[www.facebook.com/PrimaHCl](https://www.facebook.com/PrimaHCl)