

Technical Manual



PRIMA^{base}™ - Texture Coating System

Product Description

PRIMA^{base}™ is a premium quality 7.5mm thick board specifically designed as a substrate for exterior texture coating systems. PRIMA^{base}™ has 3 rebated edges for flush jointing purposes.

Applications

PRIMA^{base}™ is suitable for residential and commercial buildings of a maximum height of two storeys. Higher structures may require specific designs and therefore greater care must be exercised by the building designer and engineer to ensure the stability of the entire building system to protect sheet fixing and jointing.



Design Considerations

Fire Resistance

PRIMA^{base}™ have been tested by CSIRO Australia in compliance with AS 1503.3 and have achieved the following indices-

Early Fire Hazard Indices	
Ignition Index	0
Spread of Flame Index	0
Heat Evolved Index	0
Smoke Developed Index	0-1

PRIMA cellulose fibre reinforced cement products are deemed incombustible in accordance with the Building Code of Australia.

Vapour Barrier

In cold climates or applications where substantial temperature difference is anticipated, provide a layer of a vapour barrier on the higher temperature side of the wall. The vapour barrier will prevent condensation within the wall cavity. (Refer to Figure 1)

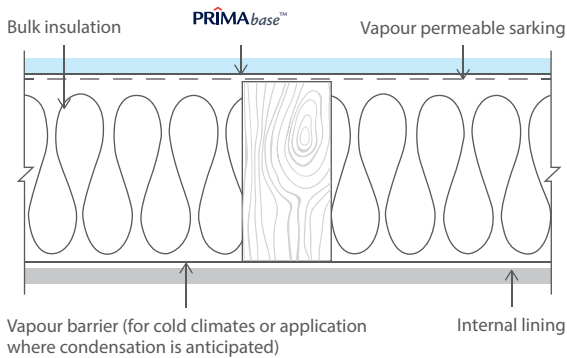

Figure 1: Typical External Wall Section

Sarking

It is recommended that a layer of vapour permeable building paper sarking be applied to the exterior side of the wall framing prior to installation of cladding material. Sarking can be of the reflective or non-reflective type. Reflective sarking such as foilbacked building paper will improve the thermal insulation properties of a wall, and protect against water ingress. Sarking must be installed as per manufacturer's instructions.

Thermal Insulation

A typical exterior wall constructed with PRIMA^{base}™ cladding, a layer of reflective building paper, 100mm timber stud and 100mm plasterboard lining will produce an R value of 0.8°C m²/W. In applications where higher thermal insulation is required, the R value may be increased by filling up the wall cavity with insulation material such as fibreglass batts. Sarking must be provided when using bulk insulation.

Example: The inclusion of R1.5 batts in the above construction will give an R value of approximately 1.8°C m²/W.

Concrete Floor Slab Detail

Sheets should be installed clear of the ground level by approximately 100mm to provide for adequate protection against constant contact with ground water. This would prevent sheets from getting saturated, which may result in coating adhesion failure. Additionally, the ground clearance would allow for early termite detection.

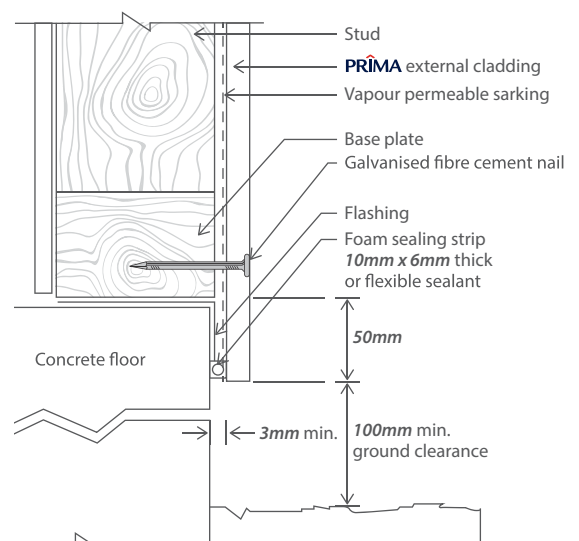

Figure 2: Bottom Plate Detail

Exterior Product Range

Painting

Under normal circumstances, **PRIMA** boards must be coated within 3 months after installation. Use exterior grade coating systems that are compatible with fibre cement cladding products. In all cases, coating manufacturer's recommendations must be strictly adhered to.

For **PRIMAbase™** board, refer to 'FLUSH JOINTING AND TEXTURE COATING SYSTEMS' section on page 18.

Maintenance

Periodic maintenance of the coating system must be performed as specified by the manufacturer. The jointing and texturing systems are also to be inspected periodically over the life of the building. All joints and sealants must be checked for cracks to prevent the intrusion of water. Make good any defects in accordance with the systems outlined in this manual and the coating manufacturer's recommendations.

Fixing Instructions

Framing

PRIMAbase™ can be applied to timber or steel framing. Framing timber must comply with AS 1684 - Residential Timber-framed Construction. To minimize shrinkage, use only kiln-dried framing timber.

Steel frame must comply with AS 3623 - Domestic Metal Framing. Steel framing must be fabricated from light gauge steel of a minimum 0.55mm to 1.60mm base metal thickness (BMT).

PRIMAbase™ must be fixed onto framing with a minimum stud face width as follows:-

- 42mm for timber studs
- 38mm for steel studs

When using narrow studs and on-stud jointing is preferred, stud face width must be increased to provide for adequate nailing (fixing) distance, this can be done by providing trim-packing to the side of the support.

Framing must be constructed with studs at maximum 600mm centres with continuous top and bottom plates. Framing stability must not be dependent on cladding material. Where necessary, provide noggings for framing stability. Refer to table 1 for details of stud spacing specification.

Window And Door Openings

Where **PRIMAbase™** boards are applied above the windows or doors, head flashing should be installed. Ensure sarking overlaps the head flashing. Flashings should be extended 50mm beyond each side of the opening and boards should be notched around the opening and sealed with paintable silicone sealant that is compatible with cementitious products.

Corner Flashings

When cladding with **PRIMAbase™**, provide metal flashing at internal and external corners. Flashing is not required if foil backed building paper is utilized as sarking.

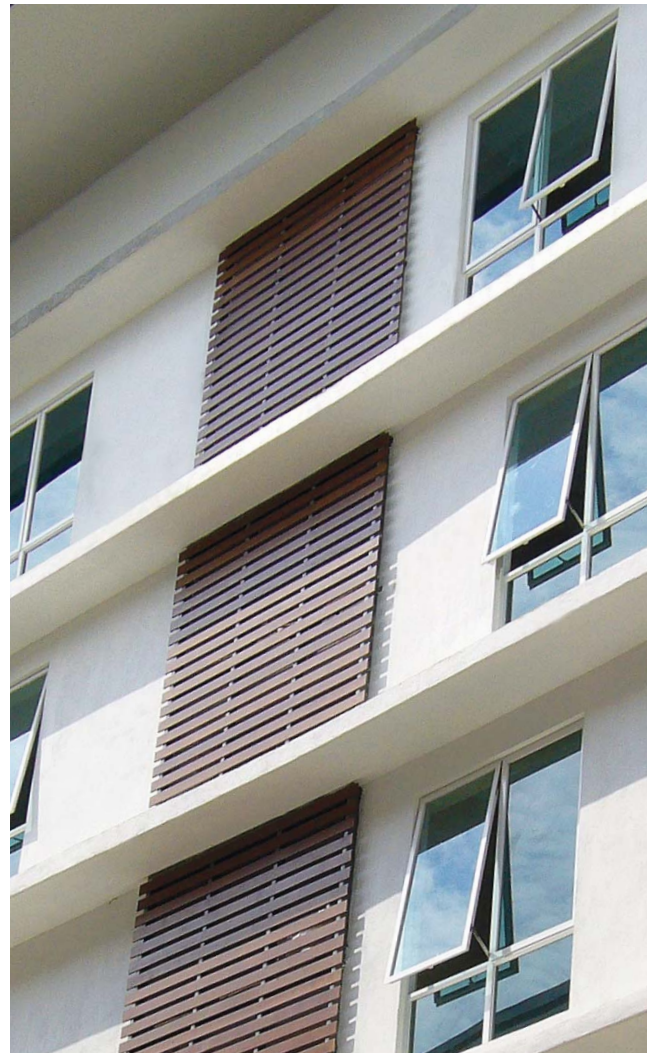

Product	Maximum Stud Spacing
PRIMAbase™	600mm

Table 1: Stud Spacing Specification

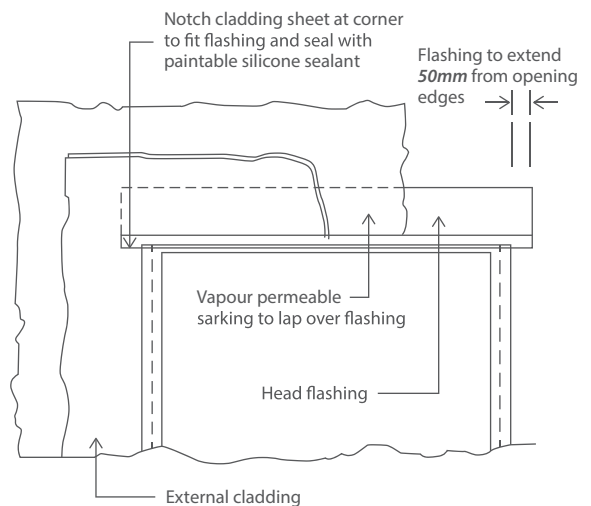



Figure 3: Head Flashing Detail

Fasteners

Fixing to Timber Framing	
Galvanised Fibre Cement Nails	Nail Size (for fixing to softwood) 
PRIMA base™	2.8mmØ x 30mm
<ul style="list-style-type: none"> • Drive nail head flush with board surface. • For recladding applications, ensure a minimum of 20mm nail penetration to the framing. 	

Fixing to Steel Framing	
Prima Fastener - Wingtek screw	Screw Size (for fixing to light gauge steel up to 1.6mm BMT) 
PRIMA base™	8 gauge x 32mm
<ul style="list-style-type: none"> • Do NOT use SEH screws with 4.5mm sheets. • Screws head must be embedded 0.5mm below sheet surface • Screws must have Class 3 finish. 	

Notes:

1. All nails shall comply with AS 2334: Steel nails - Metric Series or equivalent standards.
2. All screws shall comply with AS 3566: Self-drilling screw - for the building and construction industries.
3. In areas of severe coastal and corrosive environments, consult fastener manufacturers for recommendations.
4. To avoid undulations in finished product, fix individual sheets working from the centre towards the edge.

Working Instructions

Cutting

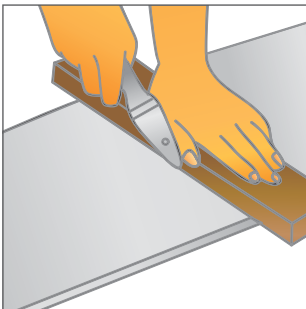

Score & Snap

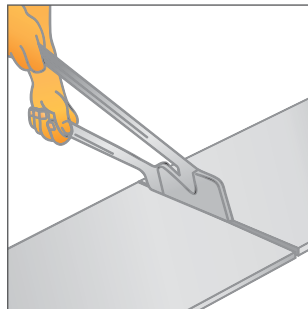

Hand Guillotine

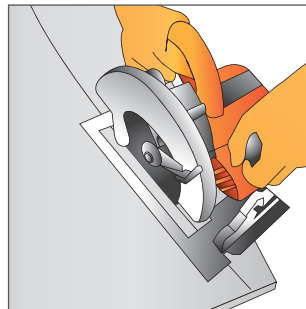

Saw Cut

Finishing

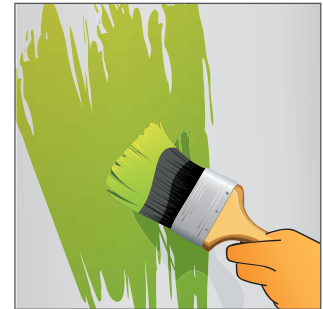

In order to achieve excellent aesthetic finishing, it is recommended to use 100% water-based quality Acrylic Paints. Generally a minimum of 2 coats is required. There is no need to apply Primers or Sealers. Please refer to paint manufacturer's install cases.

Notching & Penetrations

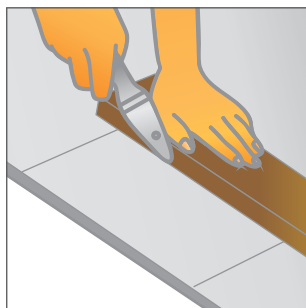

Notching

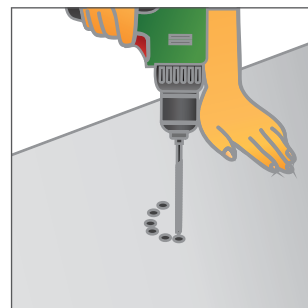

Forming Round Hole

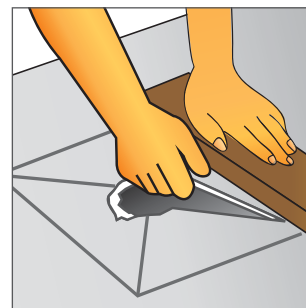

Forming Rectangular Hole

Fixing Instructions

Sheet Orientation

PRIMA^{base}™ sheets can be fixed vertically or horizontally. Generally vertical sheet layout is preferred and horizontal sheet layout is only recommended for cladding not more than 1200mm height.

Fixing Points

Fix nails or screws no closer than 12mm from the edge of the sheet and 50mm from the corner of the sheet. Fix fasteners to all studs, top and bottom plates at 200mm maximum centres. Fasteners fixing should commence from the sheets centre working outward toward the sheet edges. (See Figure 27, 28)

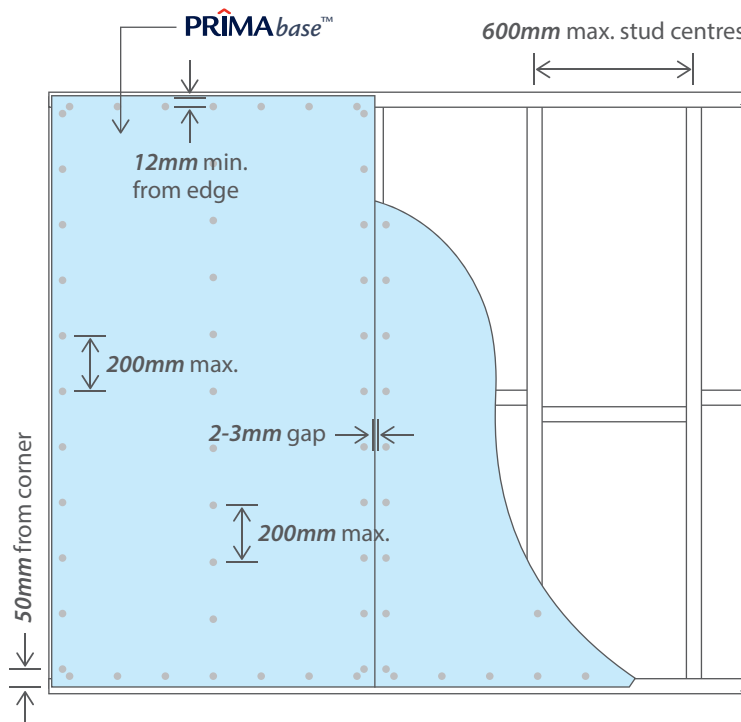

Figure 27: Vertical Sheeting

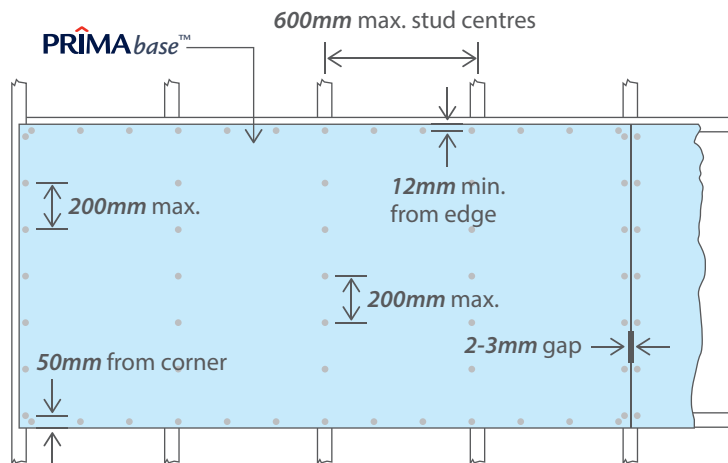

Figure 28: Horizontal Sheeting

Normal Joint

Ensure that all sheet edges join on the stud centre line. Flush joint must only be performed with rebated edge sheets. Avoid sheet joints over or near window and door corners, as these are points of stress. (See Figure 29)

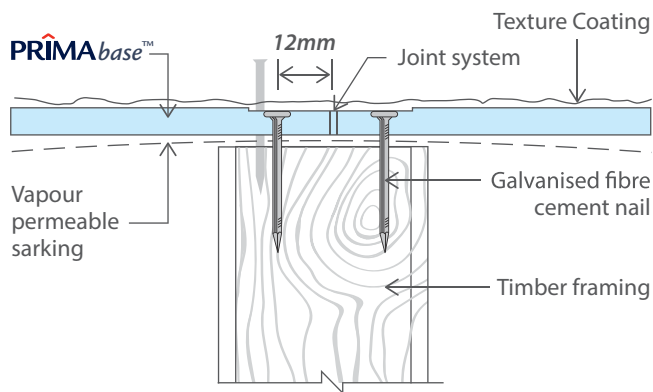

Figure 29: Normal Sheet Joint

On-site Sheet Edge Rebating

At times it may be necessary to grind a rebated edge on site. This can be achieved using an electric grinder equipped with an appropriate carborundum / diamond blade. Ensure the sheet edge retains 6.0mm minimum thickness. (See Figure 30)

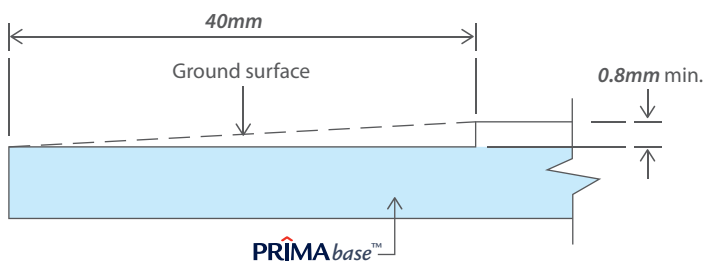

Figure 30: Square Rebated Profile





Control Joints

Minimal movement of flush jointed sheets is to be taken up by control joints. Control joints should be located at 5.4m centres and formed using sheets with square cut edges. Door and window sides are ideal locations for control joints. Provide an approximately 6mm wide gap between sheets and seal with paintable flexible sealant. Do not apply texture coating on the control joints. (See Figure 31, 32)

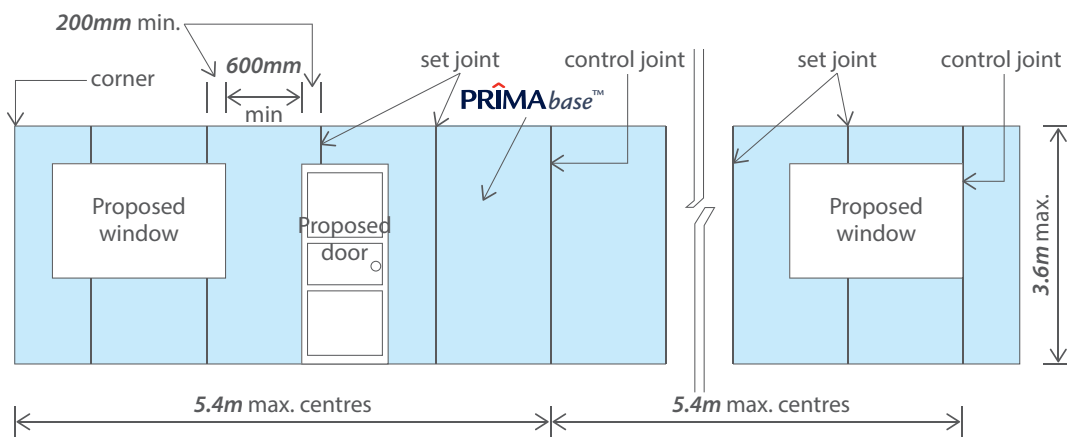

Figure 31: Sheet Layout at Openings and Control Joint Location

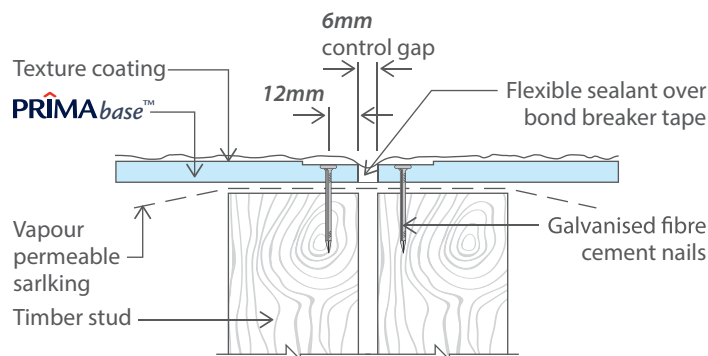

Figure 32: Control Joint Detail

Movement Joints

Vertical Movement Joints

The application of vertical movement joints is more associated with industrial and commercial constructions. These joints must be provided to cater for structural movement as and when required by the building designer. Use sheets with square cut edges to form these joints. A correctly designed movement joint will incorporate total separation of the top and bottom plates, internal lining and the **PRIMAbase™** sheet. (See Figure 33)

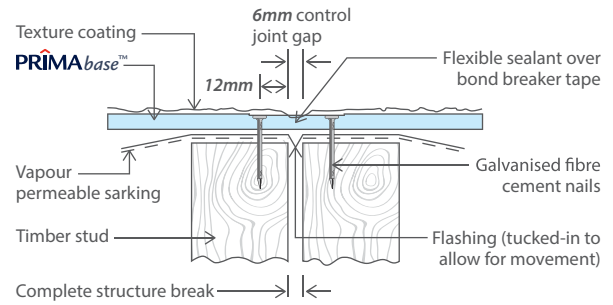

Figure 33: Vertical Movement Joint Detail

Horizontal Movement Joints

Horizontal movement joints are generally required for two-storey construction, where sheet joints occur at the floor joist line. They must be located at 3.6m maximum centres. Movement joints are particularly important to cater to any framing shrinkage or other structural movement. Alternatives on horizontal movement joints are shown in Figure 34 and Figure 35.

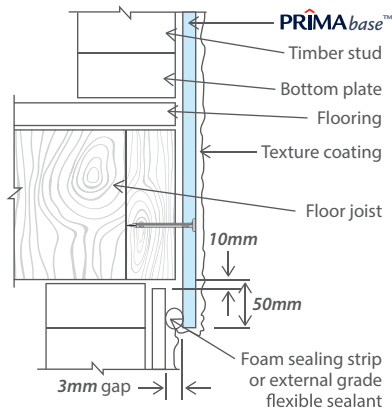

Figure 34: Horizontal Movement Joints (Option 1)

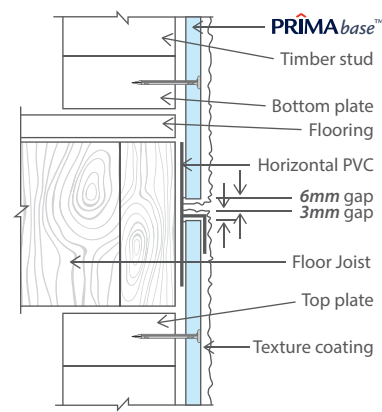

Figure 35: Horizontal Movement Joints (Option 2)

Wall Intersection Movement Joints

When **PRIMAbase™** wall intersects with an existing clad wall or masonry wall, a movement joint must be provided as shown in Figure 36 and Figure 37.

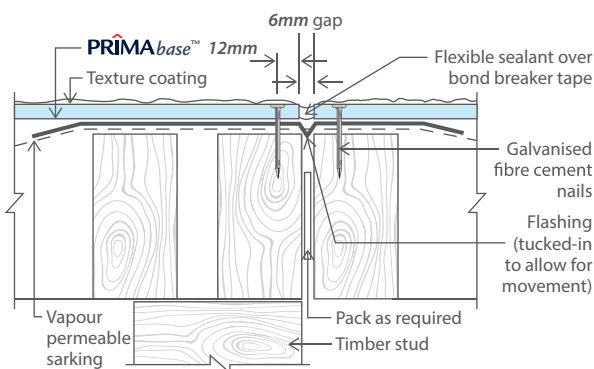

Figure 36: Vertical Movement Joints - Intersection with Clad Wall

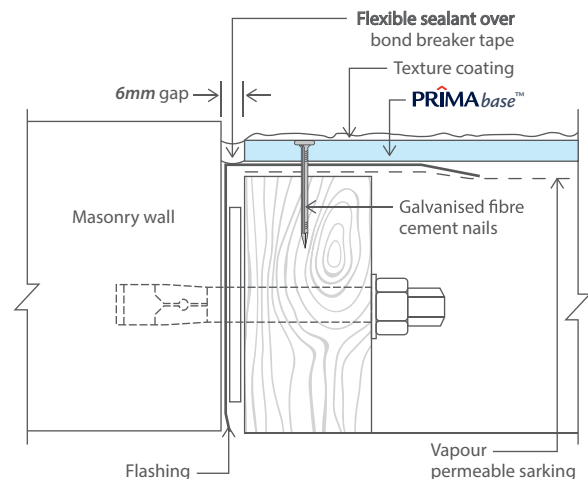

Figure 37: Vertical Movement Joints - Intersection with Masonry Wall

Window / Door Openings

Ensure that flashings are properly installed at the head, jamb and sill of an opening. Typical details at opening are shown in Figure 38 to Figure 40.

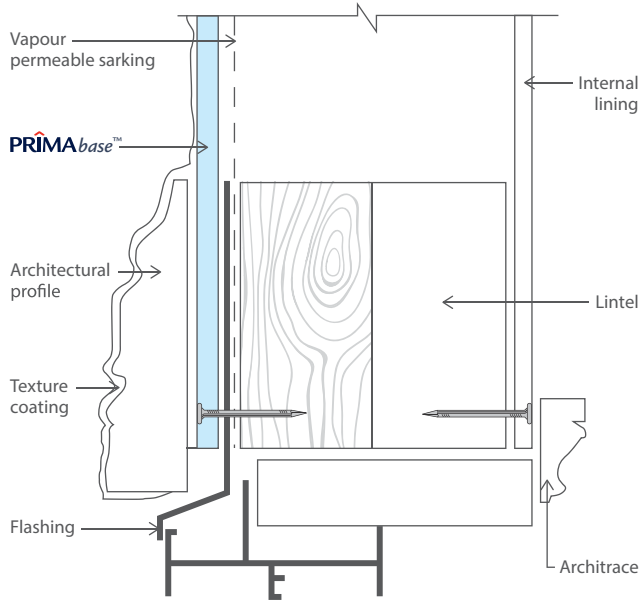

Figure 38: Window / Door Head Detail

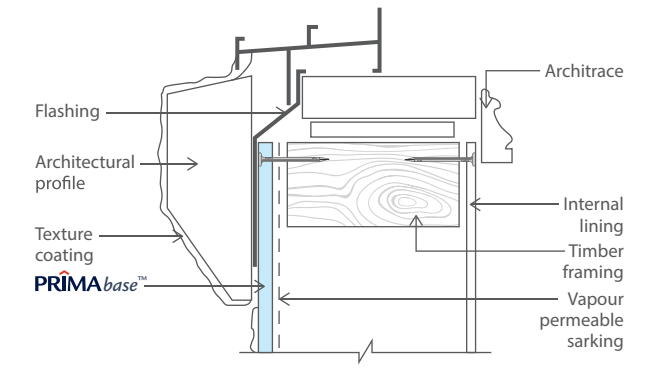

Figure 39: Window Sill Detail

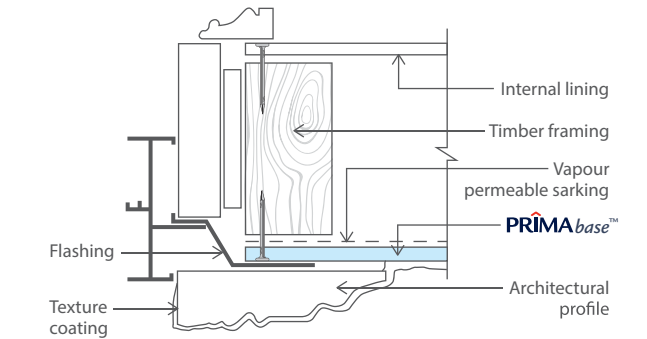

Figure 40: Window / Door Jamb Detail

Corners

PRIMAbase™ internal and external corners can either be formed using square rebated edges or cut edges. A combination of square rebated edge and cut edge is not recommended due to the difficulty when applying texture coating jointing system.

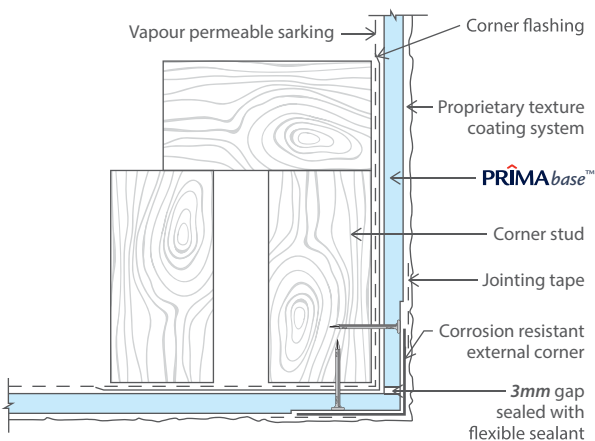

Figure 41: External Corner (PVC or Metal Angles)

External Corners

External corners are normally finished by using PVC or metal external corner angles. Use only exterior grade and corrosive resistant corner angles. Alternatively, external corners may be finished with a tape-reinforced flexible joint. Refer to Figure 41 and Figure 42.

Ensure that sheet edge is set flush with the sheet face of the other side if the corner. Provide a gap of 2mm - 3mm between adjacent sheets. Seal gap with flexible sealant.

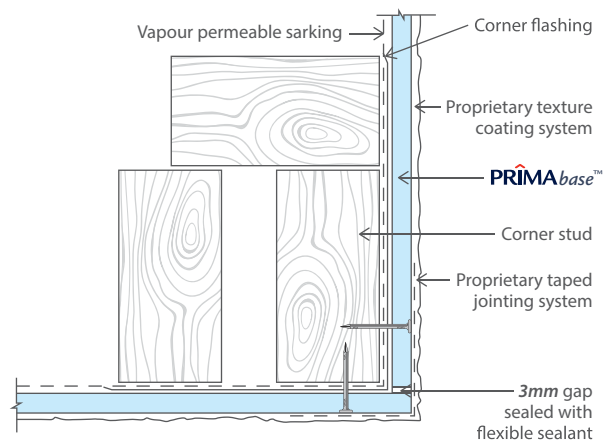

Figure 42: External Corner (Tape Reinforced Flexible Joint)

Internal Corners

Internal corner sheet joints may be set flush using tape reinforced flexible joint. Provide 2mm - 3mm gap at the adjoining sheets and seal gap with flexible sealant prior to flush setting. Refer to Figure 43.

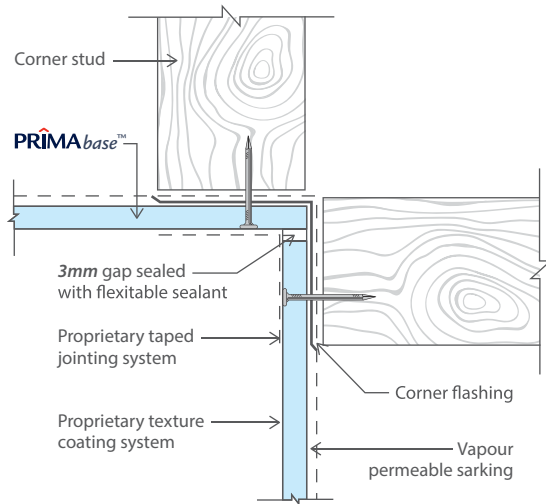

Figure 43: Internal Corner (Tape Reinforced Flexible Joint)

Flush Jointing And Texture Coating Systems

PRIMAbase™ should normally receive a sealer coat prior to application of texture coat. The texture coating must be applied to the entire **PRIMAbase™** sheet to at least the minimum thickness recommended by the coating manufacturer.

The mesh tape-reinforced joint is to be sufficiently flexible so as not to crack as a result of thermal expansion and contraction. The texture coating should generally be minimum of 3mm thick. Smooth finishes are not suitable.

Where possible avoid using dark colours due to unacceptable heat build-up. In all instances refer to the coating manufacturer's specifications and recommendations.

All jointing and texture coating applications are to be performed by manufacturer approved, reputable applicators.

Note: Ensure the jointing and coating components are from the same manufacturer and are compatible with each other.

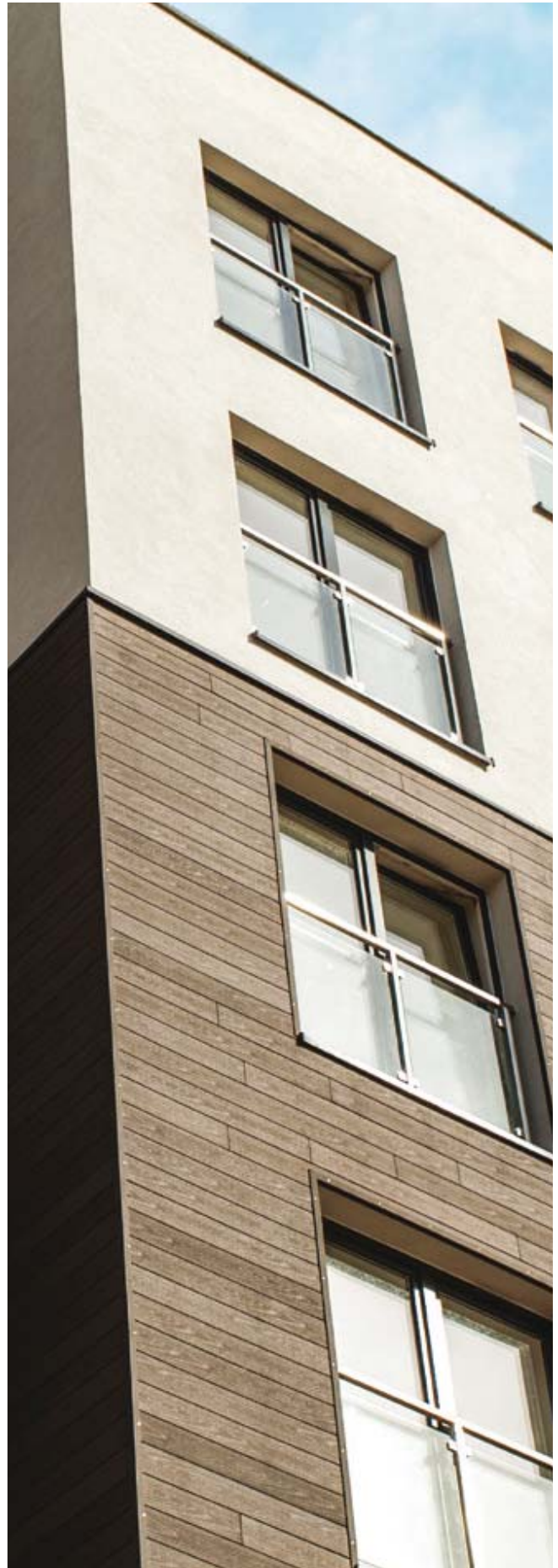

AS/NZS
2908.2

ASTM
C1186

Fire Resistance
AS 1530.3

Termite Resistance -
tested by CSIRO



CERTIFIED TO ISO 9001:2008
CERT. NO. : AR0430



CERTIFIED TO ISO 14001:2004
CERT. NO. : ER0642



Termite Resistant



Fire Resistant



Water Resistant



Weather Resistant



Environmentally
Friendly



Superior Paint
Adhesion



High Workability



Aesthetically
Pleasing



50
Years
Durability

WARRANTY

Hume Cemboard Industries Sdn Bhd ("the Company") warrants that it will at all times ensure that the products referred to herein ("the Products") shall be supplied by it to the purchaser free of any manufacturing defects and defective materials used in their manufacture.

In the event and if contrary to this assertion the Products prove to be defective, whether as a result of manufacturing defects or arising from the Company's use of defective materials, the Company will supply replacement Products. The Company shall, however, have the option and may choose to reimburse the purchaser the purchase price of the Products instead. The Company shall not be liable for any economic or consequential losses arising from any use of defective Products.

This warranty shall be void unless the purchaser has, in its handling and installation of the Products, complied with the recommendations contained in this brochure and other good building practices expected of a reasonable purchaser.

ADVISORY NOTE

Successful installations of Hume Cemboard Industries Sdn Bhd's Products depend on a large number of factors that are outside of the scope of this brochure. Particular design, detail, construction requirements and workmanship are beyond the control of the Company. As such, Hume Cemboard Industries Sdn Bhd's warranty does not extend to non-usability of Products or damage to Products arising from poor or defective designs or systems or poor quality of workmanship in the installation of Products.

The information stated in this brochure is correct at time of printing, and subject to change without notice. For the latest product update please refer to www.primafibreceement.com

For more information, please contact us at:



A Member of the Hong Leong Group

No. 12 Jalan Tandang, 46050 Petaling Jaya, Selangor, Malaysia.

Tel: +603 7781 1977, +603 7625 9999, + 603 7625 3880

Fax: +603 7625 7822, +603 7625 3990

Email: sales@humecemboard.com.my

www.primafibreceement.com

PrimaHCI

V4 1804